

## **Designing Model of Using Information and Communication Technologies in Rural Marketing Mix of Garmsar County, Iran**

R. Mohammadi<sup>1</sup>, F. Lashgarara<sup>1\*</sup>, M. Omid Najafabadi<sup>1</sup>, and R. Dinpanah<sup>1</sup>

### **ABSTRACT**

In recent years, rural marketing has gained significant importance as a driver of economic growth. However, one of the main problems in the production cycle in rural areas is inefficient marketing. Today, the quantitative and qualitative improvement in rural marketing requires accurate and up to date information. Information and Communication Technologies (ICTs) provide this information. So, survey applications of ICTs are very important in rural marketing mix. A questionnaire survey was conducted on members of rural cooperatives in Garmsar, Iran. Descriptive statistics and structural equation modelling were used to analyze the data using SPSS<sub>20</sub> and AMOS<sub>20</sub> software, respectively. The descriptive results showed that the rural marketing mix is undesirable. In addition, ICT capabilities have much role in boosting the rural marketing mix. The order of the effects of ICT capabilities on components of this mix are as follows: diffusion capabilities on the promotion (68%), and on the price (31%), location capabilities on the place (54%), and efficiency capabilities on the product (0.33%) and on the price (28%). Moreover, on the basis of the findings from the structural equation modelling, among the four ICT capabilities i.e. diffusion, location, efficiency, and financial, the impact of the financial capabilities of ICT on the price were more than that of the other capabilities (/0.77).

**Keywords:** Descriptive statistics, ICT capabilities, Structural equation modeling.

### **INTRODUCTION**

Since the beginning of this century, particularly when increasing the production of goods was based on rising demand and expanding markets, marketing has been considered to play a significant role in economic management. A market system is very important for the production process in terms of generating income for producers, creating jobs, optimal allocation of inputs to global trends, and consumer preferences.

For the rural population, improvement in the income of the agriculture and allied sectors is essential for overall economic development (Heidari *et al.*, 2017). One way

to increase rural incomes is to pay attention to the marketing. With the emergence of the green revolution, rural areas are consuming large quantities of industrial and urban manufactured products. With reference to this context, a special marketing strategy, namely rural marketing, has taken shape (Priya and Bajpai, 2013). Rural marketing incorporates the marketing of agricultural products and the rural industries' varied products. The concept now encompasses not only marketing of products that flow to the rural areas, but also products that flow to the urban areas from the rural areas (Kumar, 2013). In other words, rural marketing is a

---

<sup>1</sup> Department of Agricultural Extension and Education, Science and Research Branch, Islamic Azad University, Tehran, Islamic Republic of Iran.

\*Corresponding author; email: f.lashgarara@srbiau.ac.ir



two-way process (Durairangaswamy and Ravi, 2013).

The rise in demand for products due to the increasing population creates new employment opportunities, improves incomes, increases purchasing power, and brings about a change in the behavior of consumers, which are some of the most important contributions of rural marketing (Rani, 2013). It is not possible for a social cluster or village economy as a whole to develop without an effective and efficient rural marketing plan. Rural marketing constitutes the nerve centre of rural development activities.

Rural Marketing Mix refers to the set of actions, tactics, tools or variables that a company uses to promote and sell its brand or product in markets. It is a complex combination of Product, Place, Price, and Promotion (4P) factors that affected rural marketing (Goel and Garg, 2014).

**Product:** Product refers to anything that is capable, or can be offered, to satisfy need or want. Product for rural market must be built or modified to suit the lifestyle and needs of the rural consumers.

**Place:** Place refers to point of sale. A village as a place for promotion, distribution, and consumption is very different from town or city.

**Price:** Price refers to the amount the customers have to pay in order to acquire a product or services.

**Promotion:** This refers to all the activities undertaken to make the product or service known to and preferred amongst the user and trade (Goel and Garg, 2014).

Presently, good quality and reliable information on each aspect of agricultural activities starting from crop planning to marketing is necessary (Ali, 2013). Villages and towns are required to increase contacts through networking to ensure the flow of goods to and from rural areas (Manappa, 2012). Information and communication technologies make this possible. ICTs are defined as communications equipment and information technology, and their main functions are the creation, exchange,

storage, analysis, evaluation, management, control, transmission, reception, and distribution of data or information (US Access Board, 2015).

Chhachhar *et al.* (2014), observed that the Internet, mobile phones, radio, and television are the most important communication tools required to provide knowledge and information to farmers. In addition, it becomes easier to access information from the Internet regarding prices, markets, and other such details that can be quickly released. Vasavada (2014) stated that ICTs can aid rural marketing in multiple ways; for example, ICT has helped to improve market access and provide a wide range of information for decision-making, which is beneficial to calculate risk.

Goyal and Gonzalez-Velosa (2013) signified that ICTs can play a major role in promoting agricultural productivity and rural development. By closing information gaps and reducing transaction costs, ICTs can improve the opportunities for farmers in the agricultural markets and empower smallholders. The findings in Jha (2013) study stated that ICTs can be used to help various sectors, such as agriculture and cottage industries in the rural markets by supporting decision-making, providing market information, empowering rural consumers, dissemination of knowledge, creating new job opportunities, and increasing income for farmers, which are important in rural marketing and for fostering a turning point in achieving rural economic power.

Lashgarara *et al.* (2011) explained that ICT improved agricultural marketing through the delivery of new methods of agricultural products advertising e.g. advertising by way of email and mobile phone, information on selling products, increasing the yield of agricultural products (adopting the new principles of marketing can lead to increased yields), developing local and national markets (establishing connections with the global markets), and identifying needs of consumers.

Samuel (2010) concluded that e-commerce allows villagers to use the online marketing system to sell their products and to keep abreast of the marketing environment while on the farm.

Limited access to markets is one of the main challenges of economic development of rural areas in Iran (Namdar and Sadighi, 2013). In Garmsar County, as part of the country, one of the main problems in the production cycle is marketing. It is essential to offer products at affordable prices, at the right time, and to authentic market. Some existing problems in the rural marketing of the Garmsar County include supply to unsuitable markets at poor prices, identification and selection of the market, and the lack of production in accordance with customers' requirements. It can be stated that these problems are caused by the lack of access to market information e.g. customer needs, selling price, packaging and grading, lack of identification of relevant markets, and inappropriate distribution.

Therefore, an evaluation of the marketing mix is essential, because it will help to increase the efficiency and effectiveness of rural marketing. The aim of this study was to identify the role of ICTs in a rural marketing mix. The objectives of the study were to survey and address the situation of the rural marketing mix and capabilities of ICT in it.

## MATERIALS AND METHODS

The methodology of this study will be discussed in terms of the study area, population, sampling and data collection, data analysis, and validation and reliability of the measurement. The framework was based on a literature review, and the opinions of experts and marketers (Figure 1).

### Study Area

This study was conducted in Garmsar County, Iran. There are 101 permanent and 5 seasonal villages in the Garmsar city; thus, many people are occupied with agriculture, horticulture, livestock, and crafts. The main economic activity is agriculture, and many people directly or indirectly depend on it. In terms of cultivated area and agricultural production, Garmsar County is considered

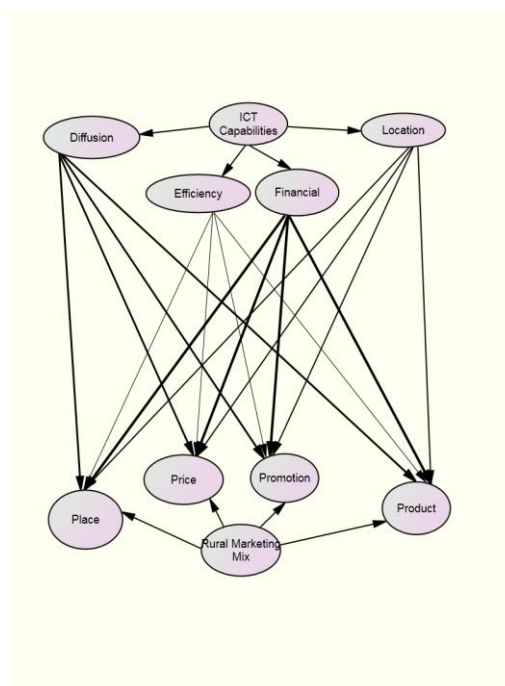

Figure 1. Theoretical research model.

as a center of agriculture and ranks second in the Semnan province.

### Population, Sampling and Data Collection

The statistical population consisted of 140 rural cooperative members working in the field of rural marketing who applied ICTs in their activities, in Garmsar County. Due to the limited population size, the research did not have sampling i.e. the sample was equal to the population and a census method was used ( $N = n = 140$ ). The main tool used in this study was a questionnaire; the questions were designed in the Likert scale format.

### Data Analysis

This is an applied study. The methods of analysis used in this study involved a combination of descriptive and quantitative research. Descriptive statistics and Structural Equation Modeling (SEM) were used for data analysis. The dependent variable of this



study was the rural marketing mix, which was measured by the perception of the respondents from approximately 24 statements. The independent variables in this research study were ICT capabilities in four sectors: financial, efficiency, location, and diffusion. The study hypotheses were measured by studying the relationships between variables and their direct and indirect effects of the analysis by SEM. Following data extraction, descriptive statistics and structural equation analysis was conducted using the SPSS<sub>20</sub> and the AMOS<sub>20</sub> software, respectively.

### Validation and Reliability of Measurement

Content and face validity were established by a panel of experts comprising faculty members and a few specialists in rural marketing. A pilot study was conducted with 30 individuals for determining the reliability of the questionnaire. The theta coefficients for each section were between 81 and 90%.

### RESULTS

Results showed that 94.42% of the respondents were male, 81.8% had the International Computer Driving License (ICDL) skills, 58.6% were bachelors, 37.1% had 13-18 years of work experience, and

52.4% spent 1-5 hours a day on the Internet.

Based on the collected information; most of the respondents (82%) believed that the current situation of the rural marketing mix was undesirable. Table 1 illustrates the respondents' points of view on the rural marketing mix.

Table 2 illustrates the ICT capabilities in the rural marketing mix from the rural cooperatives members' points of view. In Table 2, most of the respondents (56%) believed that ICT capabilities played a significant role in the rural marketing mix.

In order to identify the ICT capabilities in the rural marketing mix (4P), SEM analysis was conducted. In the present study, ICT capabilities were divided into four parts: diffusion, location, efficiency, and financial. Figure 2 shows the structural equation modelling of the study in standardized coefficient estimates. Based on the results of SEM, improving knowledge and awareness of actors in the field of product (0.79) was the most important result of the application of efficiency capability of ICTs in the product. Besides, improving the pricing of goods in the rural markets (0.81) was the most important result of the use of financial capability of ICTs in the price. With regard to location capability and diffusion capabilities of ICTs, the most important results of the application of ICT capabilities were, respectively, improvement in market access (0.63) and notification about rural marketing (0.76).

**Table 1.** Members of rural cooperatives' points of view on rural marketing mix (n= 140).

Situation	Frequency	Percent	Cumulative percent
<b>Undesirable</b>	<b>106</b>	<b>82.0</b>	<b>82.0</b>
Fairly desirable	24	16.0	98.0
Desirable	10	2.0	100.0
Total	140	100.0	

**Table 2.** ICT capabilities in rural marketing mix (n= 140).

Situation	Frequency	Percent	Cumulative percent
Low	39	26.0	60.7
Moderate	25	18.0	100.0
<b>High</b>	<b>76</b>	<b>56.0</b>	
Total	140	100.0	

Mode: Much.

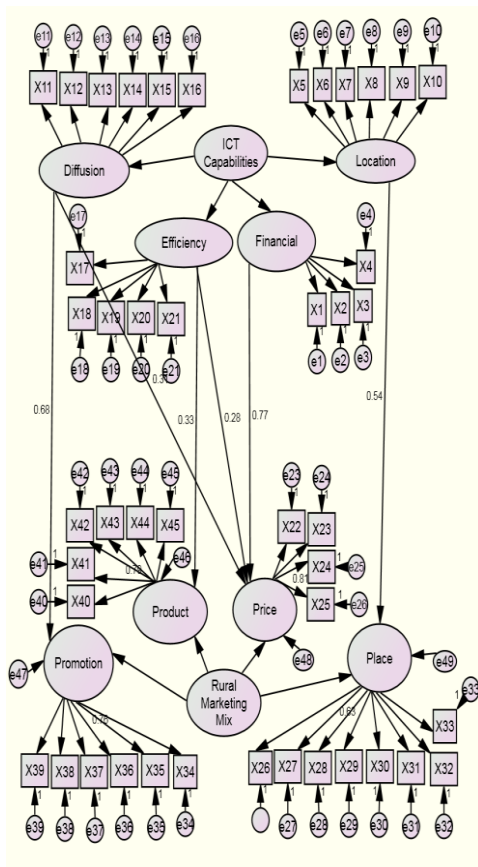

Figure 2. Structural equation model for estimated standard coefficients.

are significant and the other paths are not significant (Table 3).

The research results showed that the financial capabilities of ICT had the strongest effect on the price in rural marketing mix (0.769). Diffusion capabilities of ICTs were the second strongest factor influencing the promotion (0.678). Location capabilities of ICTs ranked the third strongest factor influencing the place (0.542). The fourth ICT capability influencing the rural marketing mix was the efficiency capability of the product (0.329). The fifth influential capabilities were the diffusion capabilities on the price, and the sixth leading capabilities influencing the rural marketing mix were the efficiency capabilities of the price (Table 4).

Model evaluation is one of the most unresolved and difficult issue connected with structural modelling. The following goodness of fit measures were used in this research to show the appropriateness of the research model (Table 5).

In this study, ‘P value’ equals 0.076 (greater than 0.05) and indicates a perfect fit of the model.

DISCUSSION

As shown in Table 3, the following paths

The research results showed that the

Table 3. Regression weight and significance test of paths.

Path	Estimate	SE	CR	P value
Financial capabilities of ICT Product	0.011	0.01	1.1	0.267
Financial capabilities of ICT Price	0.705	0.081	8.729	***
Financial capabilities of ICT Place	0	0.01	0	0.835
Financial capabilities of ICT Promotion	0.001	0.002	0.5	0.629
Efficiency capabilities of ICT Product	0.14	0.012	6.27	***
Efficiency capabilities of ICT Price	0.49	0.095	4.27	***
Efficiency capabilities of ICT Place	0.117	0.184	0.633	0.530
Efficiency capabilities of ICT Promotion	0.106	0.109	0.973	0.331
Location capabilities of ICT Product	0.226	0.814	0.278	0.781
Location capabilities of ICT Price	0.175	0.154	1.133	0.257
Location capabilities of ICT Place	0.904	0.057	16.47	***
Location capabilities of ICT Promotion	0.115	0.182	0.631	0.528
Diffusion capabilities of ICT product	1.298	1.278	1.016	0.310
Diffusion capabilities of ICT Price	0.46	0.064	7.13	***
Diffusion capabilities of ICT Place	1.225	1.232	0/994	0.320
Diffusion capabilities of ICT Promotion	0.71	0.108	6.6	***

\* P < 0.05; \*\* P < 0.01, \*\*\* P < 0.001.



**Table 4.** Standardized regression weights of significant paths.

Paths	Estimates
Financial capabilities of ICT      Price	0.769
Diffusion capabilities of ICT      Promotion	0.678
Location capabilities of ICT      Place	0.542
Efficiency capabilities of ICT      Product	0.329
Diffusion capabilities of ICT      Price	0.314
Efficiency capabilities of ICT      Price	0.283

**Table 5.** Goodness of fit measures for model evaluation.<sup>a</sup>

Goodness of fit measures	RMSEA	CMIN/DF	GFI	AGFI	NFI	CFI	P
<b>Amount</b>	0.033	1.13	0.862	0.823	0/832	0.978	0/076

financial capabilities of ICT have effect on the price in rural marketing mix. ICTs have connected the markets and distribution networks resulting in a direct connection between the farmers and buyers, and the dealers have been eliminated from the process. Rural products are affected by the experienced price fluctuations. Actors with knowledge of the product and requirements for the annual imports of the products would be able to predict the pricing of the products, which is possible through ICT. Also, ICTs will lead to increased sales by opening ultra-local and local markets in villages, and bring financial services to the rural consumers. Moreover, ICT provides the possibility of selling products online, search for new knowledge of market opportunities, and heading towards improved competitive and pricing conditions. Jyothi (2014), Oyeyinka and Bello (2013), Qiang *et al.* (2011), Fengying *et al.* (2011), Rizvi (2011), Sife and Kiondo (2010), and Vilaseca-Requena (2007) presented similar results.

Media is a significant part of most ICT diffusion capabilities, and it is very important in rural marketing. The use of social media as part of a marketing strategy has increased significantly in the past years. A large section of the target population can be quickly introduced to rural markets by them. Media also helps in changing the attitudes about the use of rural products, enhancing the culture of rural products, generating interest and encouraging people to use most of the rural products. Today,

ICTs have a lot of media coverage, and social media and networks have a growing role in marketing, which has important implications for how consumers, channels, and companies perform. In media settings, consumers provide feedback about products. All of the aforementioned reasons show that ICTs have positive effect on promotion and price in rural marketing mix. This is in line with the research by Boora (2014), Sivanesan (2014), Zanelo and Serinivason (2013), Kaushik and Dev (2013), and Katengeza *et al.* (2011).

Updated and timely information is the key to success in marketing, and ICTs provide the required information actor about marketing product. ICTs have the ability to manage high volumes and complex marketing information, awareness of new methods of agricultural and handicrafts development, providers of information on the production and post-production of goods, and assistance to farmers with reference to planned production and risks-aversion, re-engineering their production, management and organization processes and increase knowledge on the use of new technologies. In addition, people acquire higher levels of knowledge and ‘e-learning’ by means of ICTs. Finally, ICTs will lead to improved quality of production and services and pricing. So, diffusion capabilities of ICTs are factor influencing the promotion and price in rural marketing mix. The results are consistent with the findings of Tauffiqu and Pandery (2014), Chhachhar *et al.*

(2014), Ranga and Pradhan (2014), Jyothi (2014), Oyeyinka and Bello (2013), and Ekbia and Evans (2009).

ICTs Location capabilities reduce distribution costs, connect the markets and distribution networks, facilitate access to consumers and markets, provide trade links between institutions and markets, and awareness of markets and their products in other areas, thus, they have positive effect on place. Musingafi and Zebron (2014), and Mohammadi and Pirkhezranian (2012) presented similar results.

### CONCLUSIONS

In conclusion, this study contributes to the literature on rural marketing mix. All of the above findings can be useful for identifying applications of ICTs. Based on the findings of this study, we conclude that ICTs and their applications offer a platform to support marketing mix in the rural regions, both in the agricultural and other sectors. The study also established a positive relationship between ICTs capabilities and rural marketing mix. Furthermore, the study results indicate that marketing mix components like price, promotion, place, and product are affected by ICTs capabilities (efficiency, financial, diffusion, and location) and ICT improves them.

### ACKNOWLEDGEMENTS

The authors wish to thank the Department of Rural Cooperatives and their members in Garmsar, for providing the data used in this study.

### REFERENCES

1. Ali, J. 2013. Farmers' Perspectives on Quality of Agricultural Information Delivery: A Comparison between Public and Private Sources. *J. Agr. Sci. Tech.*, **15**: 685-696.
2. Boora, K. K. 2014. Leveraging ICT in Rural and Agriculture Market of India: An Overview. *IJRMST*, **2(2)**: 56-60.
3. Chhachhar, A. R., Barkatullah, Q. and Khushk, G. M. 2014. Impact of Information and Communication Technologies in Agriculture Development. *JBASR*, **4(1)**: 281-288.
4. Durairangaswamy, M. A. and Ravi, A. K. 2013. Rural Marketing: A Step towards Economic Restoration. *IJMER*, **3(4)**: 19-20.
5. Ekbia, H. R. and Evans, T. P. 2009. Regimes of Information: Land Use, Management, and Policy. *Inform. Soc.*, **25(5)**: 328-343.
6. Fengying, N., Li, Z., Jiaying, B., Fujiang, L. and Xiaochao, T. 2011. Evaluation of a Rural Information Project in Ningxia, China. In: "Strengthening Rural Livelihoods: The Impact of Information and Communication Technologies in Asia", (Eds.): Grimshaw, D. J. and Kala, S. Practical Action Publishing Ltd, Company Reg. England, PP. 109-132. DOI: <http://dx.doi.org/10.3362/9781780440361.007>.
7. Goel, A. and Garge, P. 2014. Rural Marketing: The Changing Scenario. *JBS*, **1(1)**.
8. Goyal, A. and Gonzalez-Velosa, C. G. 2013. Improving Agricultural Productivity and Market Efficiency in Latin America and the Caribbean: How ICTs Can Make a Difference?. *JRGE*, **2**: 172-182.
9. Heidari, N., Amirnejad, H. and Hosseini, A. 2017. Determination of Optimal Pattern of Conventional Agrarian Activities of Forest Fringe Villagers in Hezarjarib Area, Iran. *J. Agr. Sci. Tech.*, **19**: 11-20.
10. Jha, M. 2013. The Role of ICT in Rural Market with Reference to Bihar. *ABHINVA*, **2(1)**: 75-84.
11. Jyothi, K. C. 2014. A Study on Problems and Prospects of Rural Co-Operative Marketing. *IOSR -JEF*, **11**: 15-18.
12. Katengeza, S., Okello, J. J. and Mensah, R. 2011. Factors Influencing Awareness and Use of Electronic Based Market Information Services for Farming Business in Malawi. *Int. J. Econ. Res.*, **2(4)**: 43-58.
13. Kaushik, M. and Dev, K. 2013. Effective Media for Rural Communication: A Study of Panipat Area. *IJCEM*, **16(5)**: 7-11.
14. Kumar, P. 2013. Challenges and Opportunities of Indian Rural Market. *IJMS*, **5(3)**: 161-173.





15. Lashgarara, F., Mohammadi, R. and Omidi Najafaba, M., 2011. ICT Capabilities in Improving Marketing of Agricultural Production of Garmsar Township, Iran. *Ann. Biol. Res.*, **2(6)**: 356 – 363.
16. Manappa, O. 2012. Rural Marketing in Indian Corporate Word; Issue and Challenges. *JEMS*, 1(4).
17. Mohammadi, C. and Pirkhezranian, C.L. 2012. The Effects of ICT in Rural Development with Emphasis on Rural Society of Iran. *National Conference on Rural Development*, Gilan University, Rasht
18. Musingafi, M. C. C. and Zebron, S. 2014. The Role of Information and Communication Technology in Rural Socio-Economic Development in Africa. *Int. J. Publ. Pol. Admin. Res.*, **1(2)**: 38-46
19. Namdar, R. and Sadighi, H. 2013. Investigation of Major Challenges of Rural Development in Iran Utilizing Delphi Technique. *J. Agr. Sci. Tech.* **15**: 445-455
20. Oyeyinka, R. A. and Bello, R. O. 2013. Farmers Use of ICTs for Marketing Information Outlets in Oyo State, Nigeria. *Agr. Sci.*, **5(11)**: 150-158.
21. Priya, L. and Bajpai, V. 2013. *Impact of Rural Marketing on Indian Economy*. Institute of Technology, Kanpur.
22. Qiang, C. Z., Kuek, S. C., Dymond, A. and Esselaar, S. 2011. *Mobile Applications for Agriculture and Rural Development*. Report No: 96226-GLB, World Bank ICT Sector Unit, World Bank, Washington, DC.
23. Ranga, M. and Priyank, P. 2014. Generating Solutions for Rural Development through ICT in India. *JWEIBE*, **3(2)**: 25-32
24. Rani, M. 2013. Rural market: the Core of Indian Market Global. *GJCMP*, **2(6)**: 123-125
25. Rizvi, S. M. H. 2011. LifeLines: Livelihood Solutions through Mobile Technology in India. In: “*Strengthening Rural Livelihoods: The Impact of Information and Communication Technologies in Asia*”, (Eds.): Grimshaw, D. J. and Kala, S. IDRC, Ottawa, PP. 53-70.
26. Samuel, A. I. 2010. Using ICTs to Bridge the Agricultural Extension Gap and in Providing Market Access for Rural Farmers in Nigeria: A Practical Approach. [Available on: <http://ardyis.cta.int/ressources/publications-cles/item/82-using-icts-to-bridge-the-agricultural-extension-gap-and-improving-market-access-for-rural-farmers-in-nigeria-a-practical-approach#>]. Accessed 24/11/2011
27. Sife, A. S. and Kiondo, E. 2010. Contribution of Mobile Phones to Rural Livelihoods and Poverty Reduction in Morogoro Region, Tanzania. *EJISDC*, **42(3)**: 1-15.
28. Sivanesan, R. 2014. Problem of Rural Market in India. *IJRBSM*, **1(2)**: 1-7.
29. Tauffiqu, A. and Pandery, J. K. 2014. A Study on Application and Role of ICT in Rural Development. *JETIR*, **1(6)**: 455-458.
30. US Access Board. 2015. *Information and Communication Technology (ICT) Standards and Guidelines*. [Available on: <http://www.access-board.gov>]
31. Vasavada, J. K. 2014. A Study on Rural Market in India: Opportunities and Challenges *PIJR*, **3(3)**: 72-73.
32. Vilaseca-Requena, J., Torrent-Sellens, J. and Jime, A. I. 2007. ICT Use in Marketing as Innovation Success Factor. *EJIBM*, **10(2)**: 268-288.
33. Zanello, G. and Srinivasan, C. S. (2013) Information Sources, ICTs and Price Information in Rural Agricultural Markets. *EJDR.*, 26 (5): 815-831.
- 34.



## طراحی مدل بکارگیری فناوریهای اطلاعات و ارتباطات در آمیخته بازاریابی روستایی شهرستان گرمسار، ایران

ر. محمدی، ف. لشگرارا، م. امیدی نجف آبادی و ر. دین پناه

### چکیده

در سالهای اخیر، بازاریابی روستایی بعنوان محرک رشد اقتصادی اهمیت قابل توجهی را بدست آورده است. از سوی دیگر یکی از مشکلات اصلی چرخه تولید در مناطق روستایی، بازاریابی ناکارآمد است. امروزه، بهبود کمی و کیفی در بازاریابی روستایی نیازمند اطلاعات به روز و صحیح است. فناوری اطلاعات و ارتباطات این اطلاعات را فراهم می کند. بنابراین بررسی قابلیت‌های ICT در آمیخته بازاریابی روستایی بسیار مهم است. ابزار اصلی بکارگرفته شده در این مطالعه پرسشنامه بود. پرسشنامه توسط اعضای تعاونیهای روستایی شهرستان گرمسار، ایران هدایت شد. آمار توصیفی و مدل یابی معادلات ساختاری برای تجزیه و تحلیل داده ها و به ترتیب با استفاده از نرم افزار SPSS20 و AMOS20 استفاده شد. نتایج توصیفی نشان داد که آمیخته بازاریابی روستایی نامطلوب است. علاوه بر این، قابلیت‌های ICT نقش زیادی در ارتقای آمیخته بازاریابی روستایی دارند. اثرات قابلیت‌های ICT در اجزای آمیخته بازاریابی عبارتند از: قابلیت‌های نشر در تبلیغات (68٪) و در قیمت (31٪)، قابلیت‌های مکان یابی بر مکان/توزیع (54٪) و قابلیت‌های بهره وری در محصول (33٪) و بر روی قیمت (28٪). همچنین بر مبنای یافته های حاصل از مدل یابی معادلات ساختاری، در میان چهار قابلیت ICT (نشر، مکان یابی، بهره وری و مالی)، تاثیر قابلیت‌های مالی روی قیمت بیشتر از سایر قابلیت‌هاست (0.77٪).